

# Flexible Metal Hose, Profiling and Coiling Machines SRMV

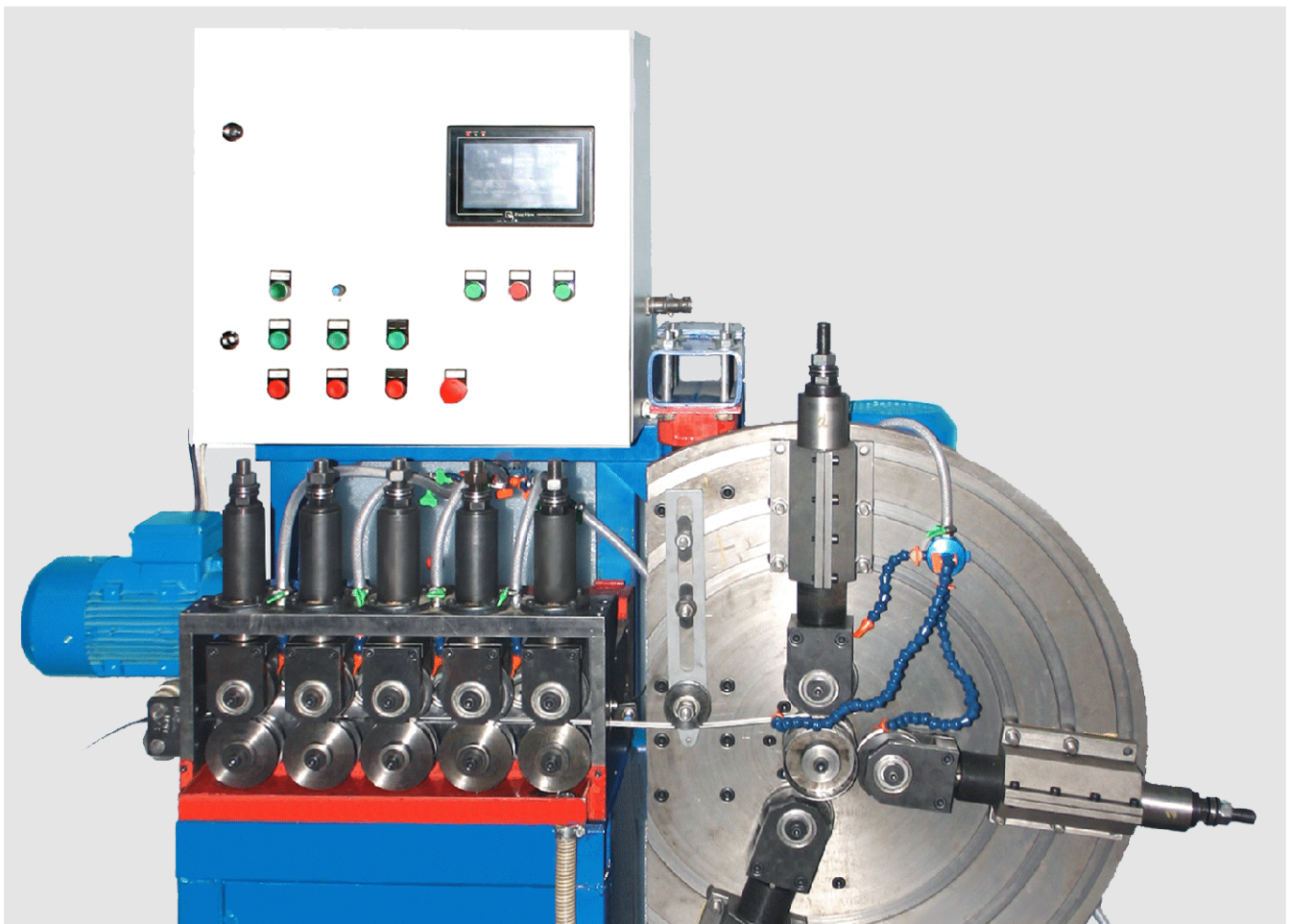

## 1. Purpose and description

SRMV machines are used to produce flexible stripwound metal hoses from the metal strip, which is profiled in the production process and rolled helically in a flexible tubing. The connection and sealing between coils of spiral is achieved due to different lock types.

The raw material for the hose production is a steel strip with a thickness from 0.1mm to 0.5mm and width up to 40mm.

The strip material can be: low-carbon steel, stainless steel, brass, copper, aluminum, galvanized, nickel-plated, aluminum-backed or other steels with a tensile strength from 300 to 600N/mm<sup>2</sup> and more than 20% elongation.

Maximal material feed speed is 50 meters per minute.

Interlock metal hoses made with SRMV machines can be used as protective hoses for all types of lines from different mechanical damages; widely used in exhaust systems and flexible ventilation tunnels; and also to transport granulated materials, gases of all kinds at temperatures from 0 до 923K (-270 °C to +650 °C)

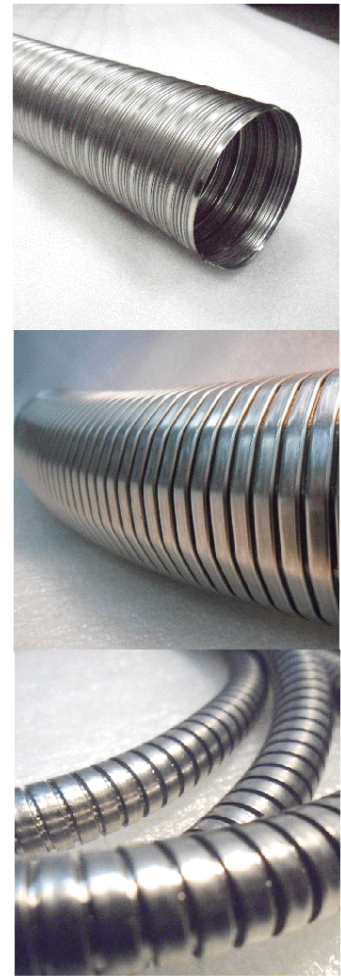

## 2. Design features

### Machine structure

- ⊗ Independent motors for profiling and coiling mandrel;
- ⊗ In mechatronic complex there are :
  - 1 independent drive mechanism for profiling process based on asynchronous motor;
  - 1 independent stepping motor for coiling drive;
  - 3 stepping motors for driving coiling rollers;
  - 3 stepping motors to control press force of coiling rollers.
  - Total: 1 asynchronous and 7 independent stepper motors;;
- ⊗ Adjustment mechanisms of pressure force for coiling rollers and profiling rollers;
- ⊗ System of liquid lubricant-coolant feeding for coiling rollers and profiling rollers;
- ⊗ No chain drives and no need to couplings' service;
- ⊗ The machine stops automatically in case of strip end;
- ⊗ Compact and space-saving design of the machine.

Schematic view and dimensions for model SRMV.4.50-150.A:

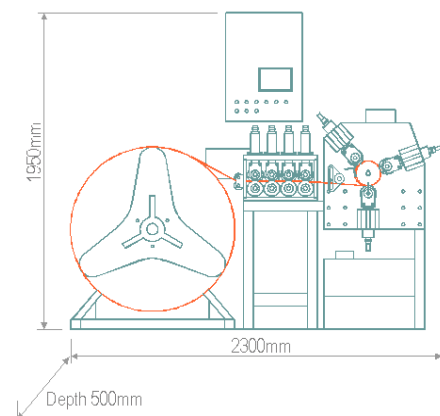

## 2. Design features

### Optional equipment

- ☞ Plasma device for automatic hose cutting to length during the coiling process (without stopping the machine);
- ☞ Uncoiling device for metal strip;
- ☞ Take-up unit for DN 5-30 hose coiling;
- ☞ Take-up unit (6m long) for DN 20-360 hose taking;
- ☞ Marking roller to mark the strip during hose making process.



### Control

- ☞ Touch screen panel with assistive user interface for hose size selection and settings loading in control system;
- ☞ Continuous adjustment of material feed speed.

### Tooling

- ☞ Replaceable tooling is made from Cr12Mo1V1 steel (DIN 1.2379) and go through heat treatment of 55-60 HRC, with strict adherence of high- quenching and tempering;
- ☞ Profiling and coiling rollers are assembly unit. Roller's profile is formed by built-up plates. Plates are made with precision method of surface and circular grinding. In case of critical wear it's possible to order and replace worn-out plates (no need to replace the entire roller);
- ☞ Guaranteed life of plates under continuous operation:
  - Profiling rollers - 1 year;
  - Coiling rollers 3-4 months (if making polygonal hose) and 1 year (if making round hose)



### 3. SRMV designation

The designation of SRMV machines consists of the following:

#### Profiling mechanism type

- SRMV.3** profiling mechanism with 3 pairs of rollers, for RMV3 hose production;
- SRMV.4** profiling mechanism with 4 pairs of rollers, for RMV1, RMV2, RMV3 hoses production;
- SRMV.5** profiling mechanism with 5 pairs of rollers, for RMV1, RMV2, RMV3 hoses production;
- SRMV.6** profiling mechanism with 6 pairs of rollers, for RMV1, RMV2, RMV3, RMV4(SSS) and RGMV1 hoses production;
- SRMV.7** profiling mechanism with 7 pairs of rollers, for RMV1, RMV2, RMV3, RMV4(SSS) and RGMV1 hoses production..

#### Coiling mechanism type

- 5-30.4D** for round hoses DN5-30 production, 4-coordinated;
- 20-100** for round and polygonal hoses DN20-100 production;
- 50-150** for round and polygonal hoses DN50-150 production;
- 70-360** for round and polygonal hoses DN70-360 production;
- 70-360.2D.U** for multiangular hoses DN70-360 production, 2-coordinated, multipurposed, long-stroked.

#### Coiling process control system types

- A** Semi-automatic control system for the production of round and polygonal hoses DN 20-360mm, with manual adjustment of coiling system by the use of spring-cylinders;
- MFA** Multifunctional automatic control system for the production of multiangular hoses DN 20-360mm, with automatic adjustment of coiling system by the use of pneumatic cylinders;
- Mechatron** Mechatronic complex for high-precision control of coiling process during production of round hoses DN 5-30mm, with exactly repeated parameters of hose's flexibility, with automatic adjustment of coiling system.



### 3. SRMV designation

Designation example of SRMV machine for round square-locked hoses DN 20-100mm production, with 3 pairs of profiling rollers, with automatic control system. This model recommended for making wiring protecting metal hoses:

**SRMV.3.20-100.A**

Designation example of SRMV machine for round and polygonal square-locked and double interlocked hoses DN 50-150mm production, with 4 pairs of profiling rollers, with automatic control system. This model recommended for making metal hoses for exhaust systems:

**SRMV.4.50-150.A**

The same as previous, with additional pair of rollers for marking metal strip:

**SRMV.5.50-150.A**

Designation example of SRMV machine for round square-locked and double interlocked hoses DN 5-30mm production, with 5 pairs of profiling rollers, strip marking, with 4-cordinated adjustment of axis feed profiled strip to coiling mechanism, with automatic adjustment of coiling system. This model recommended for making stainless metal antivandal hoses:

**SRMV.5.5-30.4D.Mechatron**

Designation example of SRMV machine for round, polygonal, multiangular; square-locked, double interlocked, double interlocked SSS profile hoses DN 70-360mm production, with 6 pairs of profiling rollers, with 2-cordinated adjustment of axis feed profiled strip to coiling mechanism, with multifunctional control system of coiling process. This model recommended for making ventilation, extraction and delivery hoses:

**SRMV.6.70-360.2D.MFA**



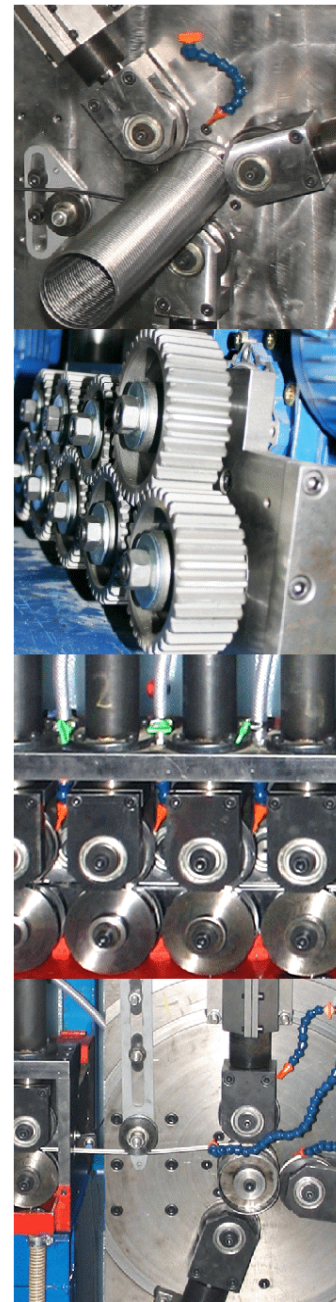

The same as previous, with additional pair of rollers for marking metal strip during production double interlocked SSS profile hose:

**SRMV.7.70-360.2D.MFA**

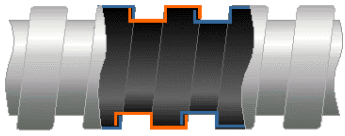

## 4. Hose sizes and profiles

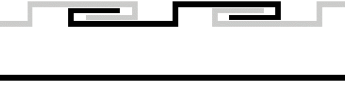
Metal hose profiles: **R** round **P** polygonal **M** multiangular

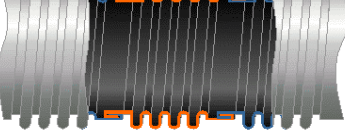
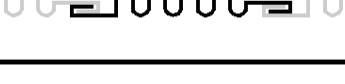
Metal hose type and profile	Control type	Profiling system type					
		SRMV.3	SRMV.4	SRMV.5	SRMV.6	SRMV.7	
<b>RMV3</b>  	Coiling	A	R P	R P	R P	R P	R P
		MFA	R P M	R P M	R P M	R P M	R P M
		Mechatron	R	R	R	R	R
	Marking		✓	✓	✓	✓	✓
<b>RMV1, RMV2</b>  	Навивка	A		R P	R P	R P	R P
		МФА		R P M	R P M	R P M	R P M
		Мехатрон		R	R	R	R
	Маркировка			✓	✓	✓	
<b>RMV4 (SSS)</b>  	Навивка	A			R P	R P	
		МФА				R P M	R P M
		Мехатрон				R	R
	Маркировка						✓
<b>RMGV</b>  	Навивка	A			R	R	
		МФА				R M	R M
		Мехатрон				R	R
	Маркировка						

ООО "ПП "Гибкие Соединения"  
+7 (495) 730-58-52  
[www.joinflex.ru/eng/](http://www.joinflex.ru/eng/)

# Flexible Metal Hose, Profiling and Coiling Machines SRMV

Russia, Moscow, 2012

